



Contact thermometers are temperature measuring instruments, which determine the temperature of a medium through direct contact with it. In order to display the temperature, they first need to acquire the temperature of the medium. Thus, only the temperature of the temperature sensor (stem) is actually being measured.

This measuring principle is based on the zeroth law of thermodynamics. It states that there is a thermal exchange between systems with different temperatures until they are in thermal equilibrium.

Since thermometers are not completely immersed in the medium, further systems such as ambient and installation conditions affect the measuring result. For a good measuring result, it is crucial to minimise interfering influences. In the following, there will be specific information on the proper design of temperature sensors for gas-actuated and bimetal thermometers.

1. Immersion Depth of the Temperature Sensor

The temperature-sensitive part of the temperature sensor defines its **active length La**. La varies depending on the measuring principle, the temperature range of the thermometer and the **diameter of the temperature sensor dF**.

Specific values can be found in the data sheets.

In terms of a metrologically precise temperature sensing, the **immersion depth Et** of mechanical temperature sensors into the medium should be 2.5x dF longer than La, however at least 20 mm.

Of course, there exist difficult installation conditions. Metrologically optimal immersion depths are not feasible everywhere. Often, very short temperature sensors are requested, whose immersion depth is reduced to the active length La. This is why the minimum lengths Lmin/L1min, specified in the data sheets, are based on the length La – in line with the industry standard.

The metrologically optimal immersion depths can be realised with temperature sensors with the following order lengths:

$$L \geq L_{min} + 2.5 \times dF \text{ or } L_1 \geq L_{1min} + 2.5 \times dF$$

for $dF \geq 8 \text{ mm}$

$$L \geq L_{min} + 20 \text{ mm or } L_1 \geq L_{1min} + 20 \text{ mm}$$

for $dF < 8 \text{ mm}$

For shorter temperature sensors, several aspects have to be taken into consideration:

- The level of the measuring error crucially depends on the process and the measuring point arrangement on site and is thus beyond the control of the manufacturer.
- Physically induced differences between indicated temperature and medium temperature can only be minimised satisfactorily with slow temperature curves and stable ambient conditions around 23 °C.

Metrologically unfavourable installation depth

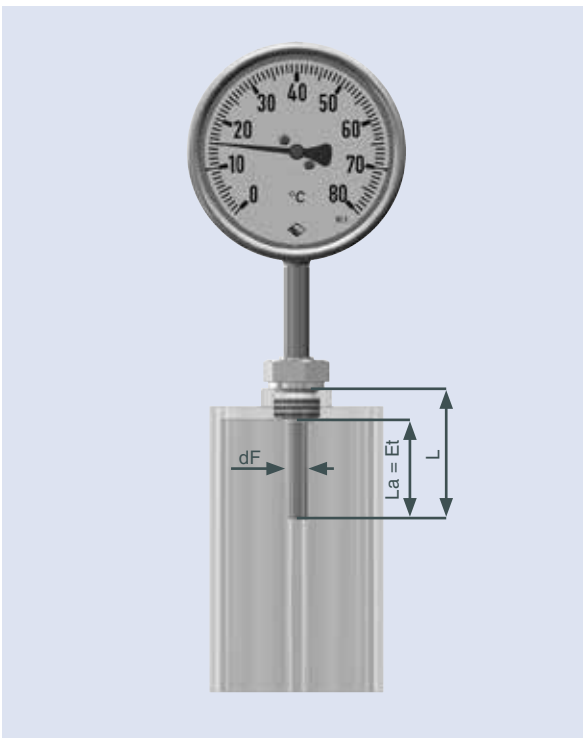

Metrologically favourable installation depth

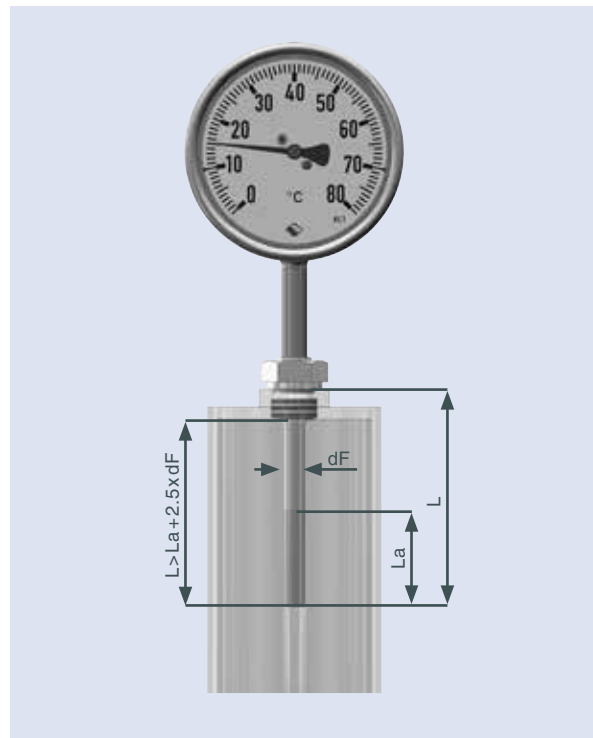

[1] F. Bernhard, Technische Temperaturmessung, Springer-Verlag Berlin Heidelberg 2014

[2] VDI/VDE 3511 Temperature Measurement in Industries 1994/96

[3] VDI/VDE 3522 Dynamic Behaviour of Contact Thermometers: Principles and Characteristic Values 2014



Sales and Export South, West, North

ARMATURENB AU GmbH

Manometerstraße 5 • D – 46487 Wesel-Ginderich
Tel.: +49 2803 9130 – 0 • Fax: +49 2803 1035
www.armaturenbau.com • mail@armaturenbau.com



Subsidiary Company, Sales and Export East

MANOTHERM Beierfeld GmbH

Am Gewerbepark 9 • D – 08344 Grünhain-Beierfeld
Tel.: +49 3774 58 – 0 • Fax: +49 3774 58 – 545
www.manotherm.com • mail@manotherm.com

2. Thermometer Design for High Medium Temperatures

Scope of application:

- MT bimetal and gas-actuated thermometers with rigid mount to the stem
- Temperature ranges with a maximum temperature of at least 400 °C

The distance between case and active length L_a has to be at least 130 mm for the above-mentioned thermometer versions. This both results from the manufacturing process and is necessary in terms of metrological parameters and application technologies.

Unsuitable device configuration

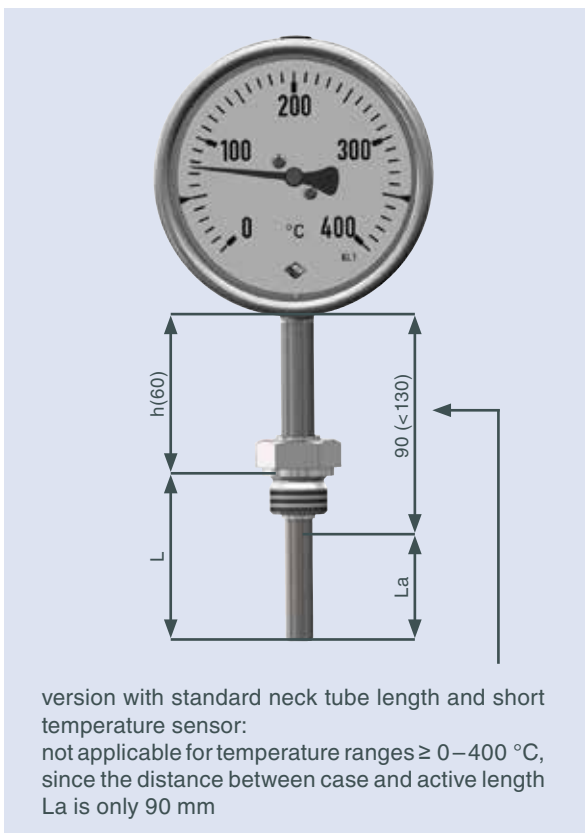

With a simple calculation it is possible to check whether the standard neck tube length h , according to the data sheet, and the requested installation length L/L_1 meet the requirements regarding the minimum distance between case and L_a . If this is not the case, you can choose between various thermometer configurations to realise the desired installation length and the necessary distance to the case.



Sales and Export South, West, North

ARMATURENBau GmbH

Manometerstraße 5 • D – 46487 Wesel-Ginderich
Tel.: +49 2803 9130 – 0 • Fax: +49 2803 1035
www.armaturenba.com • mail@armaturenba.com



Subsidiary Company, Sales and Export East

MANOTHERM Beierfeld GmbH

Am Gewerbepark 9 • D – 08344 Grünhain-Beierfeld
Tel.: +49 3774 58 – 0 • Fax: +49 3774 58 – 545
www.manotherm.com • mail@manotherm.com





Calculation of the Minimum Neck Tube Length (hb) for High Medium Temperatures

$$hb = 130 + La - L$$

Comparison with standard neck tube length:

hb ≤ h The standard neck tube length specified in the data sheet can be applied.

hb > h One of the following configurations has to be selected:

a) A3 + external neck tube

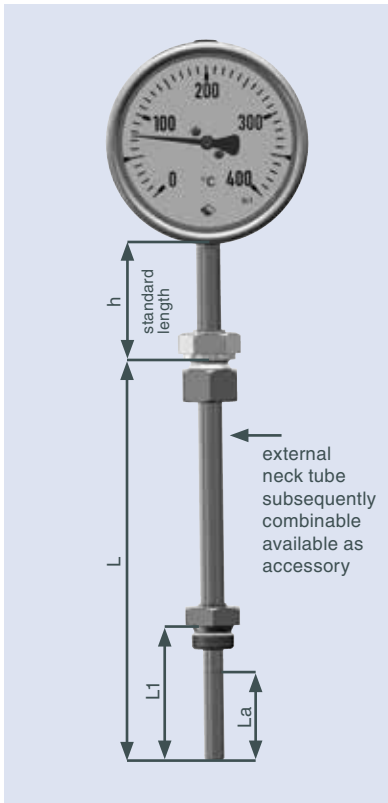

Temperature sensor model A3/B3 from L=220 mm.

This temperature sensor can be combined with one of our standardised external neck tubes to obtain a small installation length with an appropriate distance to the case.

b) A5

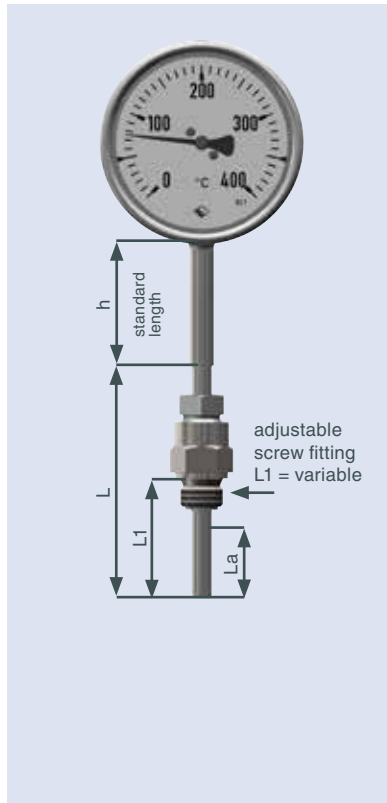

Temperature sensor model A5/B5 from L=200 mm
(adjustable connection screw fitting)

c) A4.1 with extended neck tube

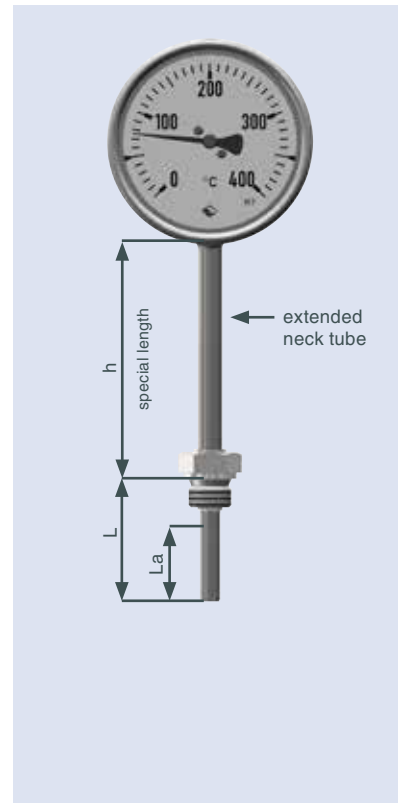

Temperature sensor (e.g. A/B 4.1) with extended neck tube

Symbols, abbreviations:

Et [mm]	immersion depth of the temperature sensor into the medium
h [mm]	neck tube length according to data sheet: connection from thermometer case to stem depending on the type also referred to as: h1, h2, h3, h6, h8, h9
hb [mm]	calculated minimum neck tube length for high medium temperatures
La [mm]	active length of the temperature sensor (depending on the type ⇒ data sheet)
L [mm]	linear dimension of the temperature sensor: installation length for one-piece thread connections and versions without thread
L1 [mm]	linear dimension of the temperature sensor: installation length for combined or variable connections
dF [mm]	diameter of the temperature sensor



Sales and Export South, West, North

ARMATURENBAU GmbH

Manometerstraße 5 • D – 46487 Wesel-Ginderich
Tel.: +49 2803 9130 – 0 • Fax: +49 2803 1035
www.armaturenbau.com • mail@armaturenbau.com



Subsidiary Company, Sales and Export East

MANOTHERM Beierfeld GmbH

Am Gewerbepark 9 • D – 08344 Grünhain-Beierfeld
Tel.: +49 3774 58 – 0 • Fax: +49 3774 58 – 545
www.manotherm.com • mail@manotherm.com