

# Bimetal Thermometer, Every Angle

TBiGelCh

Bayonet ring case stainless steel, turnable and adjustable

## Standard Versions

This data sheet contains detailed information on our standard versions and available options. In overview 8000 you will find additional information on selection, metrological features, permissible ambient and storage temperatures as well as error limits, etc. Information on the metrologically optimal design of thermometers can be found in our technical information sheet T08-000-031.

### Measuring Unit

Bimetal coil

### Accuracy (DIN EN 13 190)

Class 1

### Case

With bayonet ring, stainless steel 1.4301 (304)

### Degree of Protection (DIN EN 60 529/IEC 529)

IP65

### Nominal Case Sizes

63, 100, 160 mm (2½, 4, 6")

### Case Configuration

Connection temperature

sensor (stem):	pivot (every angle)
Stem position:	centre back position, compared to case approx. 135° adjustable and 360° turnable
Mounting device:	without

### Temperature Ranges (DIN EN 13 190)

Temperature differences from 60 K up to 600 K

### Temperature Sensor (Stem)

Made of stainless steel 1.4571 (316Ti)

Max. static operating pressure: 25 bar

Stem models: B1, B3, B4, B4.1, B5 or B6

Stem Ø dF: 6 or 8 mm

Stem length L: from Lmin or L1min up to 400 mm

Please regard the minimum stem length depending on active length (La) and stem model, see page 3

### Window

Instrument glass

### Dial

Aluminum white, scale black

### Pointer

Adjustable pointer aluminum black

### Indication Adjustment (±4 %)

Externally via screw



## Ordering Information, Standard Ranges, Options

See page 4

## Special Versions and Further Options

- Other connection threads and materials upon request
- Other temperature ranges and/or special scales, e.g. dual scale °C/°F, coloured fields or ranges, dial inscriptions
- Case parts stainless steel 1.4404 (316L) upon request
- For ambient temperatures to -60 °C upon request  
For ambient temperatures below -20 °C we recommend: thermometer with crimped-on ring case models TBiGelChg or TBiGelChgG
- GOST version for Russia, Ukraine, Kazakhstan, Belarus

## Thermowells

See data sheets 8.8110ff.

[www.armano-messtechnik.com](http://www.armano-messtechnik.com)

**ARMANO**

ARMANO Messtechnik GmbH

### Location Beierfeld

Am Gewerbepark 9 • 08344 Grünhain-Beierfeld  
Tel.: +49 3774 58 - 0 • Fax: +49 3774 58 - 545  
mail@armano-beierfeld.com

### Location Wesel

Manometerstraße 5 • 46487 Wesel-Ginderich  
Tel.: +49 2803 9130 - 0 • Fax: +49 2803 1035  
mail@armano-wesel.com

**8111**

09/19

# Stem Position, Dimensional Data and Weights

## Centre Back Stem Position, with Pivot (Every Angle)

### Stem model B1 (also B5)

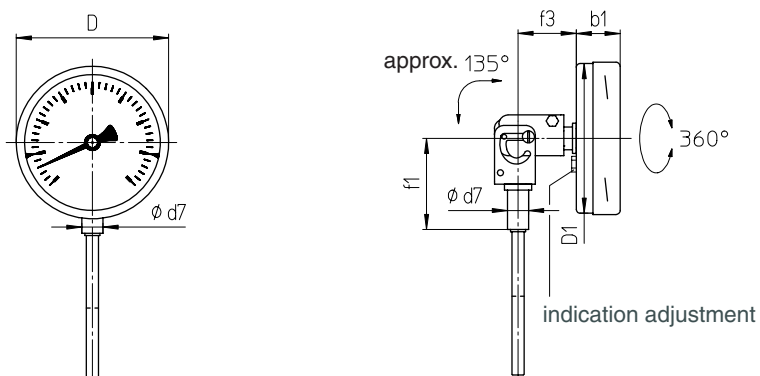

### Stem model B3 (also B6)

### Stem model B4

### Stem model B4.1

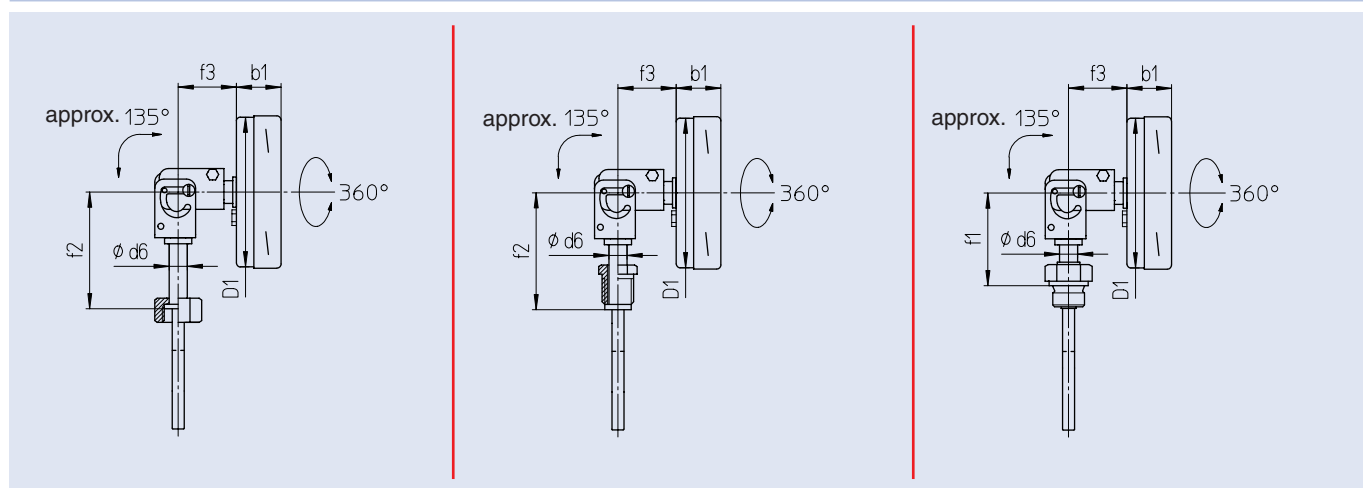

## Dimensional Data (mm) and Weights (kg)

NCS	b1	D	D1	d6	d7	f1 <sup>1)</sup>	f2 <sup>1)</sup>	f3	approx. weight <sup>2)</sup> TBiGelCh
63	26	64	62	12	14	63	80	40	0.29
100	28	101	99	12	14	63	80	40	0.42
160	27	161	159	12	14	63	80	40	0.76

<sup>1)</sup> Temperature ranges  $\geq 400$  °C: extended dimension for small stem lengths, see T08-000-031

<sup>2)</sup> The data are examples and relate to the version with stem B1, Ø 8 mm, length 100 mm.

# Stem Models

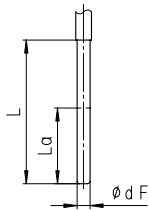
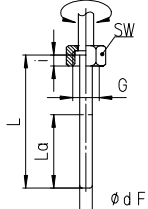
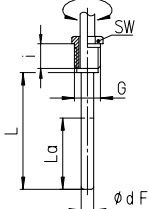
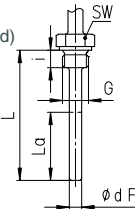
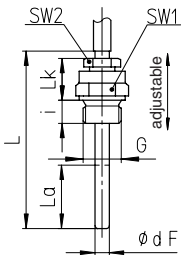
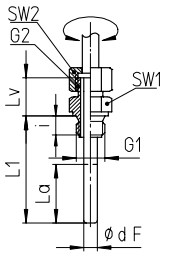
Stem Models		Without screw fitting, plain stem									
<b>Process connection:</b>	<b>Without screw fitting, plain stem</b>										
<b>Stem model:</b>	<b>B1</b>										
<b>Form acc. to DIN EN 13 190:</b>	Form 1										
<b>Stem material:</b>	1.4571										
<b>Stem Ø dF:</b>	6 or 8 mm										
<b>Order length:</b>	L										
<b>Suitable thermowell models:</b> (data sheet)	SK1 (8.8140), SK2 (8.8141) SK3.B (8.8150), SK4.B (8.8151)										
											
<b>Process connection:</b>	<b>Union nut</b>	<b>Male thread, turnable</b>			<b>Male thread, rigid</b>						
<b>Stem model:</b>	<b>B3</b>	<b>B4</b>	<b>B4.1</b>								
<b>Form acc. to DIN EN 13 190:</b>	Form 5	Form 4	Form 6 (cylindrical thread) Form 7 (conical thread)								
<b>Stem material:</b>	1.4571	1.4571	1.4571		1.4571						
<b>Stem Ø dF:</b>	6 or 8 mm	6 or 8 mm	6 or 8 mm		6 or 8 mm						
<b>Screw fitting material:</b>	1.4571	1.4571	1.4571		1.4571						
<b>Order length:</b>	L	L	L		L						
<b>Suitable thermowell models:</b> (data sheet)	SF4.1 (8.8111), SF4.1F (8.8113) SF8 (8.8130), SF9 (8.8131)	SF4 (8.8110), SF4F (8.8112) SF5 (8.8120), SF6, SF7 (8.8121)	SF4 (8.8110), SF4F (8.8112) SF5 (8.8120), SF6, SF7 (8.8121)		SF4 (8.8110), SF4F (8.8112) SF5 (8.8120), SF6, SF7 (8.8121)						
											
<b>Thread (dimensional data in mm):</b>	<b>G</b>	<b>SW</b>	<b>i</b>	<b>G</b>	<b>SW</b>	<b>i</b>	<b>G</b>	<b>SW</b>	<b>i</b>		
	G 1/2	27	10	G 1/2 B	22	20	G 1/2 B	27	14		
	G 3/4	32	12	G 3/4 B	27	23	G 3/4 B	32	16		
	M20x1.5	27	10	M18x1.5	22	14	1/2" NPT	27	19		
	M24x1.5	32	12	M20x1.5	22	20	3/4" NPT	27	19		
	M27x2	32	12	<b>Thermowell required!</b>			M18x1.5	24	14		
							M20x1.5	27	14		
<b>Process connection:</b>	<b>Male thread/compression fitting</b>			<b>Male thread, turnable/double male adapter</b>							
<b>Stem model:</b>	<b>B5</b>			<b>B6</b>							
	(B1 with compression fitting)			(B3 with double male adapter)							
<b>Form acc. to DIN EN 13 190:</b>	Form 2 (cylindrical thread) Form 3 (conical thread)			—							
<b>Stem material:</b>	1.4571			1.4571							
<b>Stem Ø dF:</b>	6 or 8 mm			6 or 8 mm							
<b>Screw fitting material:</b>	1.4571			1.4571							
<b>Order length:</b>	L			L1							
<b>Suitable thermowell models:</b> (data sheet)	SF4 (8.8110), SF4F (8.8112) SF5 (8.8120), SF6, SF7 (8.8121)			SF4 (8.8110), SF4F (8.8112) SF5 (8.8120), SF6, SF7 (8.8121)							
											
<b>Thread (dimensional data in mm):</b>	<b>G</b>	<b>SW1</b>	<b>SW2</b>	<b>i</b>	<b>Lk</b>	<b>G1</b>	<b>G2</b>	<b>SW1</b>	<b>SW2</b>	<b>i</b>	<b>Lv</b>
	G 1/2 B	27	22	14	42	G 1/2 B	G 1/2 B	27	27	14	28
	G 3/4 B	32	22	16	42	G 3/4 B	G 1/2 B	32	27	16	28
	1/2" NPT	27	22	19	42	1/2" NPT	G 1/2 B	27	27	19	28
	3/4" NPT	27	22	19	42	3/4" NPT	G 1/2 B	27	27	19	28
	M20x1.5	27	22	14	42	M20x1.5	M20x1.5	27	27	14	28
						M24x1.5	M20x1.5	32	27	14	28
						M27x2	M20x1.5	32	27	16	28
<b>Minimum Stem Length and Active Length (mm)</b>											
			<b>Stem Ø dF:</b>								
			<b>6</b>		<b>8</b>						
			<b>Span ΔT<sup>1)</sup></b>								
<b>Stem model:</b>	<b>Length:</b>	<b>Thread:</b>	<b>≥ 100 K</b>	<b>= 80 K</b>	<b>= 60 K</b>	<b>≥ 80 K</b>	<b>= 60 K</b>				
<b>all models</b>	La	all standard threads	40	60	70	40	60				
<b>B1 / B4</b>	Lmin	all standard threads	45	65	75	45	65				
<b>B3</b>	Lmin	all standard threads	52	72	82	52	72				
<b>B4.1</b>	Lmin	all standard threads	60	80	90	60	80				
<b>B5</b>	Lmin	all standard threads	95	115	125	95	115				
<b>B6</b>	L1min	all standard threads	60	80	90	60	80				
<b>others</b>			upon request			upon request					
								<b>The minimum length Lmin/L1min</b> is the smallest feasible stem length. Important: Please note the technical information sheet T08-000-031 on the metrologically optimal stem length.			
								<b>The active length La</b> is the temperature-sensitive part of the stem.			

<sup>1)</sup> The temperature difference (span) ΔT = 60 K corresponds e.g. to the temperature range 0–60 °C, but also to –20/+40 °C, see table page 4

## Ordering Information

Basic Model: Bimetal Thermometer Every Angle		TBiGelCh
<b>Case filling:</b>	without	without code letters
<b>Nominal case size:</b>	case Ø 63, 100, 160 mm (2½, 4, 6")	<b>63, 100, 160</b>
<b>Stem position/ case configuration:</b>	centre back position, with pivot (every angle)	without code letters
<b>Temperature ranges:</b>	scale: $\Delta T$ (K):	
	0 – 60 °C 60	
	0 – 80 °C 80	
	0 – 100 °C 100	e.g. <b>0–100 °C</b>
	0 – 120 °C 120	
	0 – 160 °C 160	
	0 – 200 °C 200	
	0 – 250 °C 250	
	0 – 300 °C 300	
	0 – 400 °C 400	
	0 – 500 °C 500	
	0 – 600 °C 600	
	–50 / +50 °C 100	
	–40 / +40 °C 80	
	–40 / +60 °C 100	
	–30 / +50 °C 80	e.g. <b>–30/+50 °C</b>
	–30 / +70 °C 100	
	–20 / +40 °C 60	
	–20 / +60 °C 80	
	–20 / +80 °C 100	
	50 – 300 °C 250	
<b>Stem:</b>	without screw fitting, plain stem	<b>B1</b>
	union nut	<b>B3</b>
	male thread, turnable	<b>B4</b>
	male thread, rigid	<b>B4.1</b>
	male thread/compression fitting	<b>B5</b>
	male thread, turnable/double male adapter	<b>B6</b>
<b>Stem Ø dF:</b>	6 or 8 mm	<b>dF 6, 8</b>
<b>Stem length:</b>	L or L1 in mm	e.g. <b>L = 100 mm</b>
<b>Process connection:</b>	see page 3	e.g. <b>G½B</b>
<b>Options:</b>	red mark on the dial	
	plastic clip red or green, external at the bayonet ring for NCS 100, 160	
	window laminated safety glass	
	acrylic glass (PMMA)	
	polycarbonate (PC)	
	case polished	
	bayonet ring polished	
	stem Ø dF 10 mm	
	stem length >400 mm, max. 800 mm	
	instrument tag stainless steel plate 12 x 55 mm (0.47 x 2.17") with wire mounting or sticker upon the case	

**Example:**

**TBiGelCh 80, 0–100 °C, B3, dF 8, L = 140 mm, G½**

**Special Versions:** Please describe your requirements in cleartext!