

Dead Weight Tester

Pneumatic version, portable version
Pressure range 0.03 – 1 bar

PD 1

Application

- High-precision primary standard (comparison standard)
- Reference device for calibration services, gauging offices and laboratories
- Suitable for testing, adjusting and calibrating pressure measuring instruments without using an external reference device

Construction

The main components of the dead weight tester are measuring system, valve units, pressure generation, adjusting mechanism for fine adjustment and set of weights.

The measuring system consists of a fine lapped piston/cylinder pair. The weight-loaded piston is pressed down by the local gravitation of the weights. The test pressure, which is generated and adjusted by either an electric pump, or an integrated metal bellows, or externally via the admission pressure connection, acts from below towards the piston surface area.

This test pressure is increased until the pneumatic force of the medium (usually air) on the piston surface area (acting from below) compensates the weight force of the piston/weight system and the equilibrium of forces is reached. During this state of equilibrium, the piston floats freely in the cylinder.

In order to simplify the handling, the weights are already standardised to the specific determined piston surface area and the local gravitation at the installation site. The set of weights is available discretely graduated in different pressure units (bar, Pa, psi).

Piston and weights are set in rotation by manual initiation and kept floating in order to minimise the influence of static friction of piston and cylinder and therefore to guarantee a sensitive discrimination threshold.

The dead weight tester described herein operates in a range from 0.03 to 1 bar.

Specialties

Due to the high accuracy of the dead weight tester, the influence of the gravitational acceleration is not negligible. A requirement for an official verification is the calibration of the dead weight tester with the gravitational acceleration at the installation site. Thus, this value needs to be specified when placing the order. A calibration for the installation site is recommended without official verification as well.

Without specification of the gravitational acceleration, the dead weight tester is calibrated with the value at the manufacturing site ($g_{\text{Hst}} = 9.80968 \text{ m/s}^2$). Then, the measuring values need to be converted at the installation site for the compliance with the accuracy class.

Standard Version

Set of Weights

In bar/kPa

Pressure Range

Basic load	0.03 bar
Main measuring range	0.1 – 1 bar

Reference Condition for the Guaranteed Accuracy

Ambient temperature +20 °C ±2 °C (+68 °F ±3.6 °F)

barotec
KALIBRIERTECHNIK



Accuracy (factory calibration)

Class 0.05
Class 0.02

Medium

Air

Nominal Piston Cross-section

2 cm²

Rotation of the Weights

Initiated manually

Connection

Male G ½ LH with clamping sleeve on G ½ right or M20x1.5 right, incl. double sealing

Connection for External Compressed Air

Plug connection (Prestolock) for PA hose N4x1, with adapter for N6x1

Case

Aluminum case, grey enamelled (self-supporting cover), 3 adjustable feet for precise horizontal alignment according to integrated circular level

Case Dimensions (L x W x H)

300 x 260 x 240 mm (11.81 x 10.24 x 9.45")

Approx. Weight

Dead weight tester	15 kg (33.07 lb)
Set of weights	3.1 kg (6.83 lb)
Transport case dead weight tester	2.2 kg (4.85 lb)
Transport case set of weights	2.1 kg (4.63 lb)

Technical Drawings

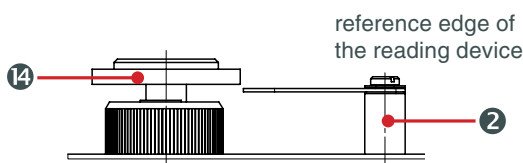
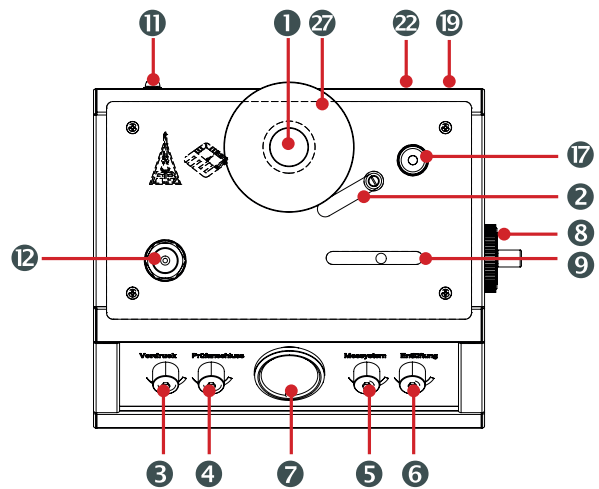
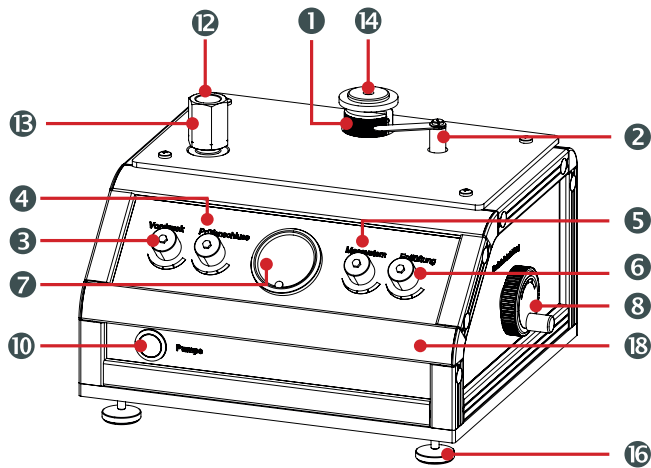

Schematic Drawing

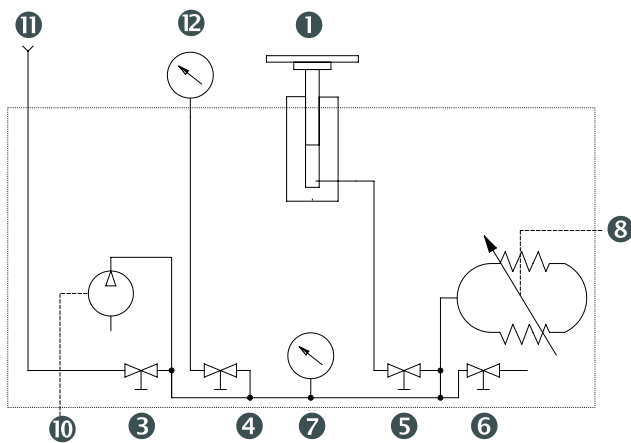

- ① Measuring system
- ② Reading device (stationary pointer)
- ③ Stop valve "Admission pressure/Vordruck"
- ④ Stop valve "Test connection/Prüfanschluss"
- ⑤ Stop valve "Measuring system/Messsystem"
- ⑥ Stop valve "Ventilation/Entlüftung"
- ⑦ Mechanical admission pressure indication (pressure gauge)
- ⑧ "Adjusting mechanism/Nachstelleinrichtung"
- ⑨ Position indication adjusting mechanism
- ⑩ Push button "Pump/Pumpe"
- ⑪ "Connection admission pressure/Anschluss Vordruck"
- ⑫ Test connection
- ⑬ Clamping sleeve (SW 27)
- ⑭ Base plate (basic load)
- ⑮ Adjustable feet
- ⑯ Circular level
- ⑰ Case
- ⑱ Electrical connection "6 V DC 500 mA"
- ⑳ Nameplate
- ㉑ Weights

Special Versions and Options

- Set of weights in kp/cm², psi; others upon request
- Adapters for other connection threads upon request
- Inspection certificate 3.1 according to DIN EN 10 204 on the indication accuracy
- Accredited calibration or DKD approval*
- Higher accuracy class 0.01 upon request
- Adapter from hose 4x1 to 1/4" NPT male

Scope of Delivery

The delivery includes – in addition to the dead weight tester and the set of weights:

- Operating instruction
- Transport case dead weight tester
- Transport case set of weights
- Special gasket for test item, with 2 encased O-rings
- Clamping sleeve G 1/2 LH / G 1/2
- Adapter for N6x1 (admission pressure connection)
- 6 V mains adapter

* see section Specialties

Ordering Information

Please specify in your order:

Basic model PD 1
Options see options

Example: PD 1
 class 0.05
 gravity acceleration at the installation site
 DKD approval certificate