



Contents

1. Information on This Operating Instruction	1
1.1 Pictographs Used in This Manual	2
1.2 Exclusion of Liability	2
2. Safety Instructions	2
3. Device Description	3
3.1 Intended Use	4
4. Technical Data	4
5. Preparation, Functions and Measuring Process	5
5.1 Test Process with Pressure	5
5.2 Test Process with Vacuum	6
5.3 Test Process with Pressure and Vacuum	6
6. Maintenance/Cleaning, Storage and Transport	6
7. Dismounting and Disposal	7
8. Declaration of Conformity	7

1. Information on This Operating Instruction

- The manual is aimed at specialists and semi-skilled personnel.
- Please read the instructions carefully before carrying out any operation and keep the specified order.
- Thoroughly read and understand the information in chapter 2 "Safety Instructions".

If you have any problems or questions, please contact your supplier or contact us directly at:

ARMATURENBAU GmbH

Manometerstraße 5

D – 46487 Wesel-Ginderich

Tel.: +49 2803 9130 – 0 // Fax: +49 2803 1035

mail@armaturenbau.com

MANOTHERM Beierfeld GmbH

Am Gewerbepark 9

D – 08344 Grünhain-Beierfeld

Tel.: +49 3774 58 – 0 // Fax: +49 3774 58-545

mail@manotherm.com



Sales and Export South, West, North

ARMATURENBAU GmbH

Manometerstraße 5 • D – 46487 Wesel-Ginderich

Tel.: +49 2803 9130 – 0 • Fax: +49 2803 1035

www.armaturenbau.com • mail@armaturenbau.com

Subsidiary Company, Sales and Export East

MANOTHERM Beierfeld GmbH

Am Gewerbepark 9 • D – 08344 Grünhain-Beierfeld

Tel.: +49 3774 58 – 0 • Fax: +49 3774 58 – 545

www.manotherm.com • mail@manotherm.com

1.1 Pictographs Used in This Manual

In this manual, pictographs are used as hazard warnings.

Particular information, instructions and restrictions designed for the prevention of personal or substantial property damage:



WARNING! Is used to warn you against an imminent danger that may result in personal injury or death.

IMPORTANT! Is used to warn you against a possibly hazardous situation that may result in personal, property or environmental damage.

CAUTION! Is used to draw your attention to important recommendations to be observed. Disregarding them may result in property damage.



The following symbol highlights **actions** you have to conduct or **instructions** that have to be strictly observed.

1.2 Exclusion of Liability

We accept no liability for any damage or malfunction resulting from incorrect installation, inappropriate use of the device or failure to follow the instructions in this manual.

2. Safety Instructions

Please read this operating instruction thoroughly before operating the comparison pump.

Disregarding the containing warnings, especially the safety instructions, may result in danger for people, the environment, and the device and the system it is connected to.

The comparison pump corresponds with the state of engineering at the time of printing. This concerns the operating mode and the safe operation of the device.

In order to guarantee that the device operates safely, the operator must act competently and be conscious of safety issues.

The MANOTHERM Beierfeld GmbH provides support for the use of its products either personally or via relevant literature. The customer verifies that our product is fit for purpose based on our technical information. The customer performs customer and application specific tests to ensure that the product is suitable for the intended use. With this verification, all hazards and risks are transferred to our customers. Our warranty expires in case of inappropriate use.



Qualified personnel:

The personnel that is charged for the installation, operation and maintenance of the comparison pump must hold a relevant qualification. This can be based on training or relevant tuition. The personnel must be aware of this manual and have access to it at all times.



General safety instructions:

- In all work, the existing national regulations for accident prevention and safety at the workplace must be complied with. Any internal regulations of the operator must also be complied with, even if these are not mentioned in this manual.
- Use the comparison pump in its perfect technical condition only. Damaged or defective instruments need to be checked immediately and replaced if necessary.
- Only use appropriate tools for mounting, connecting and dismantling the comparison pump.
- Nameplates or other information on the device shall neither be removed nor obliterated, since otherwise any warranty and manufacturer responsibility expires.



Special safety instructions:

Warnings, which are specifically relevant to individual operating procedures or activities, are to be found at the beginning of the relevant sections of this operating instruction.

Operating Instructions

Comparison Pump PH 60-P

3. Device Description

The comparison pump model PH 60-P is a pressure generator and used for comparative measurements. It is suitable for testing, adjusting and calibrating pressure measuring devices of all kinds.

The model is applicable for pressure ranges from -1 to +60 bar. For testing, only gaseous, non-aggressive media shall be used.

Gauge pressure from -0.5 bar up to +4 bar can be generated with the installed spindle pump (ambient air). An external compressed air supply and vacuum generation (vacuum pump) is required for higher pressure and vacuum ranges respectively.

The test item is compared to a pressure measuring device with higher accuracy (e.g. Overview 2000 Test Gauges, Overview 10000 Calibration Technology).

Comparison pumps on a base plate are small, light-weight, handy and can be mounted easily on a work-bench or applied mobile on site.

Components:

- ❶ Pump system (piston with spindle – turnable via handwheel – for pressure and vacuum generation and for fine adjustment, cylinder serving as pressure chamber)
- ❷ Base plate
- ❸ Connection for test item
- ❹ Connection for reference device
- ❺ Stop valve with clamping sleeve for reference device
- ❻ Stop valve with clamping sleeve for test item
- ❼ External vacuum and pressure connection
- ❽ System ventilation with connection options for a hose or a tube
- ❾ Double stop valve
Valve ❸ for connection ❸
Valve ❿ for connection ❷

All parts are mounted on a base plate ❷ and connected by tubing.

Nameplate and label:

The nameplate is placed on the back of the comparison pump. It contains the most important technical data and information.

Scope of delivery:

The delivery includes – in addition to the comparison pump:

- 1 operating instruction
- 2 special gaskets for connections, with 2 encased O-rings (mounted)
- 4 O-rings as spare parts
- 2 clamping sleeves G ½ (mounted)
- 2 clamping sleeves M20x1.5
- 2 nipples and union nuts according to DIN 16 284 for connections ❷ and ❸ (mounted)

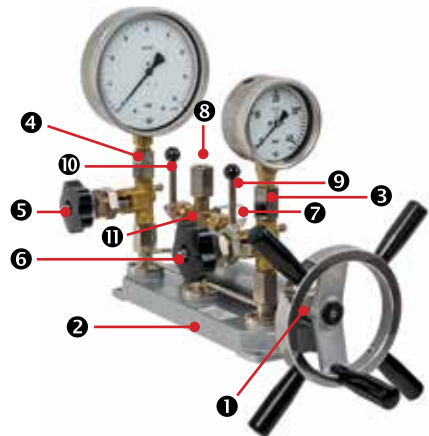

Operating Instructions

Comparison Pump PH 60-P

3.1 Intended Use

The comparison pump shall only be used for generating pressure or vacuum in order to carry out comparative measurements for testing, adjusting and calibrating pressure measuring devices.

Do not use the comparison pump beyond its specification or contrary to the operating instructions.



WARNING! No safety component!

The comparison pump is no safety component in compliance with the directive 2006/42/EC (Machinery Directive).

→ Never use the comparison pump as safety component.

The operational safety of the device supplied is only guaranteed by intended use. The specified limit values (⇒ chapter 4 "Technical Data") must not be exceeded. This particularly applies for the adherence to the permissible full scale value and the permissible temperature range.



IMPORTANT! Risk of injury or material damage due to overpressure!

Exceeding the maximum overload values may lead to material failure of the comparison pump. This may also cause serious damage to health.

→ Ensure that the overload values are never exceeded.

Please check if the comparison pump is suitable for your application before ordering and installation.

4. Technical Data

Construction type	plate version
Medium	dry, clean, non-corrosive gas
Special version for oxygen (O ₂)	wetted parts free of grease and oil
p _{min} (operating volume ≤0.1 litre)	-0.5 bar (without external vacuum supply)
p _{max} (operating volume ≤0.1 litre)	4 bar (without external pressure supply)
Required admission pressure	-1 / +60 bar (for higher pressure ranges)
Standard connection	2 connections male G ½ LH, each with 2 clamping sleeves on G ½ right or M20x1.5 right, incl. double sealing
Connection for external compressed air supply and vacuum pump	2 nipples and union nuts according to DIN 16 284 for connections ⑦ and ⑧
Base plate	all parts mounted on grey cast aluminum, 4 mounting orifices Ø 8.5 mm (0.33")
Piston and spindle	stainless steel
Cylinder	brass, grey enamelled blue enamelled ¹⁾
Weight	approx. 7 kg (15.43 lb)
Temperature range	10 °C to 50 °C (50 °F to 122 °F)

¹⁾ for the special version for oxygen

Operating Instructions

Comparison Pump PH 60-P

5. Preparation, Functions and Measuring Process

Before commissioning:

Before putting into operation, the comparison pump should be firmly mounted on the workbench via the 4 mounting orifices in the base plate **2**. Additionally, a visual inspection shall be carried out to check the integrity of the pressure-bearing connection elements.

Initial setting:

Before commissioning, close the valves **5**, **6** and **9**; open valve **10**.

Tightly screw the reference device (e.g. test gauge) into the connection of valve **5** and the test item into the connection of valve **6**.



IMPORTANT! Attention must be paid to thorough sealing! Please use an appropriate wrench and the designated wrench flat. During screwing in, the pressure measuring devices should never be held at the case!

5.1 Test Process with Pressure

Without external compressed air supply:

(Valve **9** remains closed)

For testing pressure measuring devices, the screwed out spindle is the initial position for the pressure generation in the cylinder. Close the stop valve **10**, open valves **5** and **6**, then turn the handwheel slowly clockwise.

The generated pressure is indicated on the pressure measuring devices. Before screwing out the spindle again, close the valves **5** and **6** and open valve **10**. Before generating pressure again, close valve **10** and open valves **5** and **6**. By repeatedly turning the spindle in and out, a pressure of up to max. 4 bar can be generated.

With external compressed air supply:

(Valve **9** remains closed)

If a test pressure higher than 4 bar is required, an external clean, gaseous and non-aggressive pressure supply unit needs to be attached to connection **8**. Prior to this, close valve **10**! Ensure that the connection is firm and tight! The compressed air supply via valve **10** must be carried out controlled, otherwise the pressure measuring devices are overpressurised. For fine adjustment, the spindle pump needs to be used while valve **10** is closed.

Ventilation:

The system can be ventilated with valve **9** and via connection **7**.



IMPORTANT! Never open any pressure-bearing connection as long as there is any pressure left in the system!

In particular, do not screw out the test item. Please vent the entire system always completely until no pressure is left in the system! By attaching a hose or a tube to connection **7**, it is possible to release the medium outside the test station.

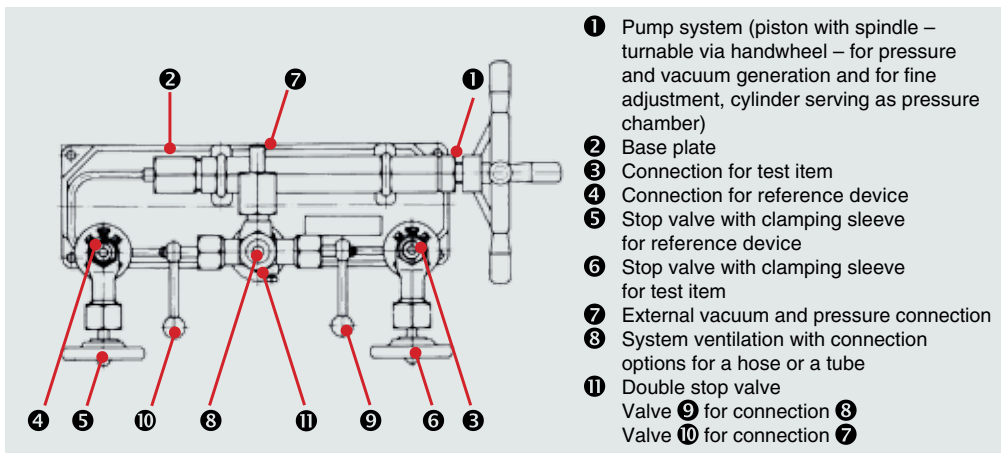

Fig. schematic drawing

5.2 Test Process with Vacuum

Without external vacuum supply:

(Valve 9 remains closed)

For testing vacuum measuring devices, the spindle screwed into the piston is the initial position for the vacuum generation in the piston. Close the stop valve 10, open valves 5 and 6, then turn the handwheel counter-clockwise. The generated vacuum is indicated on the vacuum measuring devices. Before screwing in the spindle again, close the valves 5 and 6 and open valve 10 (Disregarding this results in pressure generation!). Before generating vacuum again, close valve 10 and open valves 5 and 6. By repeatedly turning the spindle in and out, a vacuum of approximately 0.5 bar can be generated.

With external vacuum supply:

(Valve 9 remains closed)

If a test vacuum of more than 0.5 bar is required, an external vacuum pump needs to be attached to connection 3. Prior to this, close valve 10! Ensure that the connection is firm and tight! The vacuum supply via valve 10 must be carried out controlled, otherwise the pressure measuring devices are overloaded. For fine adjustment, the spindle pump needs to be used while valve 10 is closed.

Ventilation:

The system can be ventilated with valve 9 and via connection 7 (see page 5).

5.3 Test Process with Pressure and Vacuum

(Compound measuring ranges)

For testing compound gauges, an external pressure supply and an external vacuum generation supply is required.

The vacuum pump and the pressure supply are attached to the connections 8 and 7.



IMPORTANT! Valves 10 and 9 need to be closed during this process! The assignment of the connections 7 and 3 is freely selectable. Ensure that the connection is firm and tight!

The test process is carried out in the same way as described in the individual test processes above.

6. Maintenance/Cleaning, Storage and Transport



CAUTION! Material damage and loss of warranty!

Any modifications or interventions in the device, made by the customer, might damage important parts or components. Such intervention leads to the loss of any warranty and manufacturer's responsibility!

→ Never modify the device or perform any repairs yourself.

Maintenance:

The maintenance is limited to occasional lubrication of the unscrewed spindle with instrument grease (for the special version for oxygen with special grease).

The instrument cannot be repaired by the operator. In case of faults, which cannot be eliminated without interference in the device, please return the instrument to the manufacturer for repair. Any arising repairs may only be executed by the manufacturer.

Cleaning:

- Clean the comparison pump with a dry or slightly dampened lint-free cloth.
- Do not use any sharp objects or aggressive agents for cleaning.

Storage and transport:

- Use the original packaging or comparable packaging for transport.
- Avoid impacts or strong vibrations.
- Protect the device against moisture.

Operating Instructions

Comparison Pump PH 60-P

7. Dismounting and Disposal

Before dismounting:

The test item must be unpressurised before dismounting! For this purpose, open the valves **5**, **6**, **9** and **10**.

Disposal:



NO DOMESTIC WASTE!

The comparison pump comprises various materials. It shall not be disposed together with domestic waste.

→ Bring the comparison pump to your local recycling plant

or

→ send the comparison pump back to your supplier or to the MANOTHERM Beierfeld GmbH.

8. Declaration of Conformity

CE The CE marking of the instruments certifies the conformity with prevailing EU directives for placing products on the market within the European Community. The following directive applies:

2014/68/EU (PED)

The corresponding declaration of conformity is enclosed or available upon request.

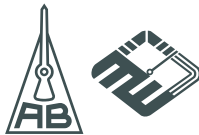

Sales and Export South, West, North
ARMATURENBAU GmbH
Manometerstraße 5
D – 46487 Wesel-Ginderich
Tel.: +49 2803 9130 – 0
Fax: +49 2803 1035
mail@armaturenbau.com
www.armaturenbau.com

Subsidiary Company, Sales and Export East
MANOTHERM Beierfeld GmbH
Am Gewerbepark 9
D – 08344 Grünhain-Beierfeld
Tel.: +49 3774 58 – 0
Fax: +49 3774 58 – 545
mail@manotherm.com
www.manotherm.com