

# Diaphragm-Seal

for Pulp and Paper Industries, DN 48, PN 40 (600 lb/sq.in.)

Model

# MDM 7590

## Application

Diaphragm seals model MDM 7590 are mainly used in the pulp and paper industry. Bourdon tube pressure gauges, pressure switches and pressure transmitters or other pressure measuring instruments can be attached.

Important information about advantages, applications, and features can be found in our model overview 7000 where you will also find an overview of our other chemical seal series.

Please note especially the explanations about the influences of temperature and other special operating conditions, and the requirement of detailed ordering information resp. inquiries.

Please use our check list for pressure measuring instruments with chemical seal to ensure the completeness of all required ordering information (for download to find at <http://armaturenbau.com>, PDF-Download). You can receive the check list in printed version with mail upon request.

## Construction

The diaphragm seal is made of a collar with connection piece for the measuring instrument, and a short extension tube to which the diaphragm is flush welded.

A filling port at the connection piece for the measuring instrument is provided for filling the complete measuring system after mounting and evacuation.

An attachment flange is used for mounting the diaphragm seal to the measuring point.



Do not open any connection of the system!  
Otherwise filling fluid will leak out and the measuring system cannot work proper anymore!

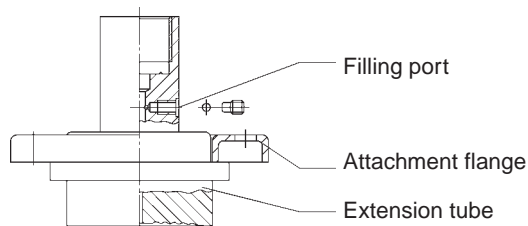

## Standard Configuration

### Process Connection

DN 48, extension tube length TuL=15 mm (.59"),  
option: TuL= 6.5 mm (.26")

### Body (Including Extension Tube)

Stainless steel 316 L (1.4435)

### Diaphragm

Stainless steel 316 L (1.4435,) flush welded to the body;  
effective-Ø dM = 38 mm (1.5")

### Attachment Flange

Stainless steel moulding, 6 holes Ø 7 mm (.28"), hole circle Ø 70 mm (2.76")

### Nominal Pressure

PN 40 (600 lb/sq.in.)

### Instrument Connection

G ½ B (½" BSP) female

### Filling Liquid

Silicone oil (FA1)



## Pressure Ranges Measuring Instrument

Pressure gauges NCS 100 (4"): 0-1.6 to 0-40 bar, 0-30 to 0-600 psi  
(also corresponding pressure/vacuum compound ranges)  
for other pressure measuring instruments upon request

## Reference Temperature

+20 °C (+68 °F), dial inscription for pressure gauges: tA 20 °C

## Optional Special Configurations e.g.:

- Instrument connection ¼" BSP female, ¼" NPT female or ½" NPT female; others upon request
- Connection 90° quadrant pipe or 90° quadrant pipe with vibration damper, for Bourdon tube pressure gauges ≤ NCS 100 (4") only, compare drawings overleaf
- Welding counter flange, massive version or with pipe welding socket (compare overleaf); other special versions upon request
- Other filling fluids, suitable to the medium
- Working temperature differing from +20 °C (+68 °F); please point out the operation conditions
- Capillary line between diaphragm seal and instrument (length limit upon request), or cooling element, see data sheet 7002, strongly recommended for medium temperatures >+100 °C (>+212 °F)
- Versions in special sizes upon request
- Special materials upon request

## How to Order:

Please note the detailed information about the required ordering information

- in our model overview 7000 and our check list for measuring instruments with chemical seal
- on the data sheet for the measuring instrument that shall be attached.

Model code: **MDM 7590**

Process connection: **DN 48**

Nominal pressure: **PN 40**

Extension tube length: **TuL 15 mm (.59"), or 6.5 mm (.26")**

Material chemical seal: **316 L**

Instrument connection<sup>1)</sup> **½" BSP-f** (others see above)

Special configurations: see above

Please point out especially when the medium or ambient temperature is different than +20 °C (+68 °F).

**Example:** MDM 7590, DN 48, PN 40, TuL15 mm, 316 L, ½" BSP-f for instrument

<sup>1)</sup> to state only for separate ordered diaphragm seals



**ARMATURENBAU GmbH**

Manometerstraße 5 • D-46487 Wesel - Ginderich  
Phone: (0 28 03) 91 30-0 • Fax: (0 28 03) 10 35  
[armaturenbau.com](http://armaturenbau.com) • [mail@armaturenbau.com](mailto:mail@armaturenbau.com)



Subsidiary Company and Sales East Germany and Eastern Europe

**MANOTHERM Beierfeld GmbH 7590**

Am Gewerbepark 9 • D-08344 Grünhain-Beierfeld  
Phone: (0 37 74) 58-0 • Fax: (0 37 74) 58-545  
[manotherm.com](http://manotherm.com) • [mail@manotherm.com](mailto:mail@manotherm.com)

3/06

# Dimensional Drawings, Dimensions and Weight

## Standard-Version

Direct mounting

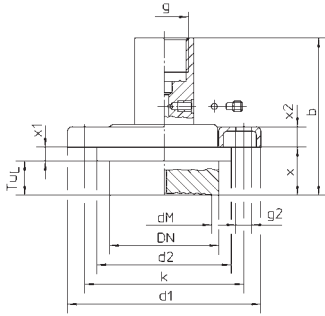

## Option

Capillary line

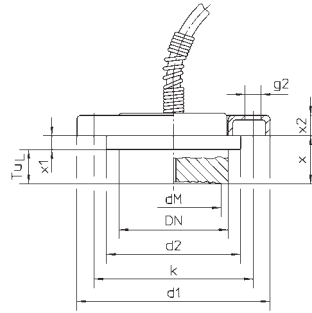

## Options

90° quadrant pipe

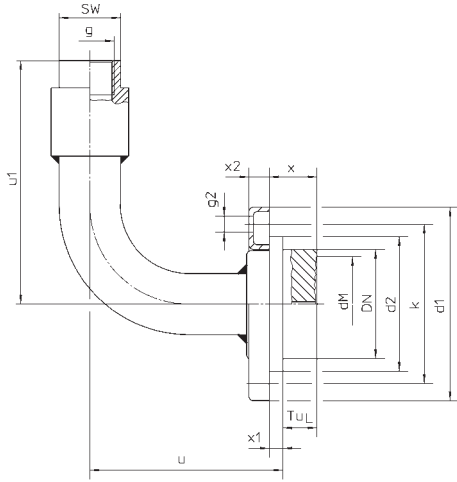

90° quadrant pipe with vibration damper for pressure gauges ≤ NCS 100 (4") only

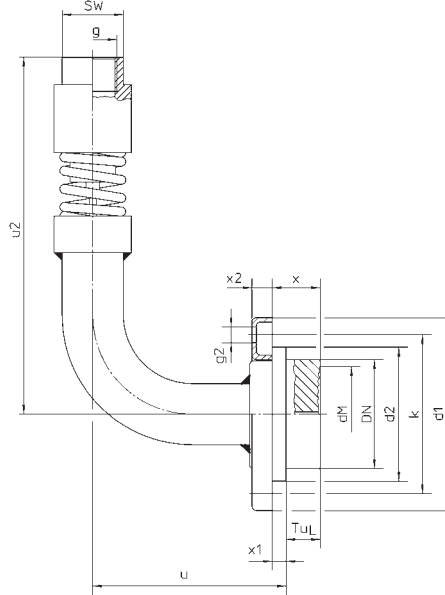

### Dimensional Data ( mm / inches ) and Weight ( kg / lb )

Extension Tube TuL:	DN	b <sup>±2</sup>	d1	d2	dM	g	g2	k <sup>±2</sup>	u <sup>±1</sup>	u1 <sup>±1</sup>	u2 <sup>±1</sup>	x	x1	x2	SW	Weight (approx.) <sup>1)</sup>
15 mm .59"	48 (1.89")	66 2.6	85	59	38	G ½ female	6 x Ø 7	70	81	107	157	21 .83	6	9	27	0.72 1.59
6.5 mm 2.6"		57.5 2.26	3.35	2.32	1.5	½" BSP-f	6 x Ø .28	2.76	3.19	4.21	6.18	12.5 .49	.24	.35	1.06	0.40 .88

<sup>1)</sup> standard version, direct mounting

## Welding Counter Flanges

Massive

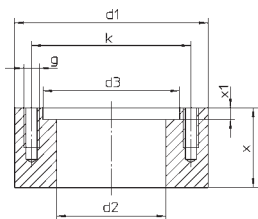

With pipe welding socket

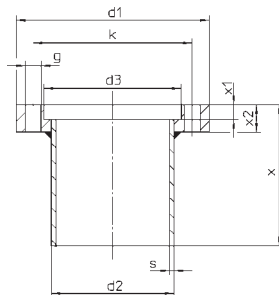

### Dimensional Data ( mm / inches ) and Weight ( kg / lb )

Version:	d1	d2	d3	g	g2	k	s	x	x1	x2	Weight (approx.)
Massive	85 3.35	48.5 1.91	59.5 2.34	6 x M6	—	70 2.76	—	35 1.38	5 .2	—	1.00 2.20
With pipe welding socket		54 2.13	60.4 2.38	—	6 x Ø 7 6x Ø .28		2 .08	55 2.17	7 .28	12 .47	0.40 .88

The information in this leaflet is given in good faith but we reserve the right to make changes without notice.